

HYDRAULIC MOTORS MT

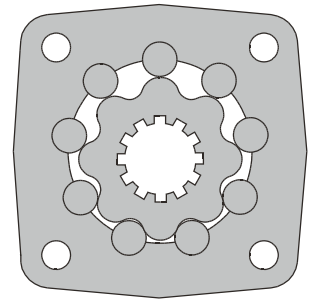

APPLICATION

- » Conveyors
- » Metal working machines
- » Machines for agriculture
- » Road building machines
- » Mining machinery
- » Food industries
- » Special vehicles
- » Plastic and rubber machinery etc.



CONTENTS

Specification data	30
Function diagrams	31 ÷ 33
Dimensions and mounting	34
Shaft extensions	35
Dimensions and mounting- MTS, V	36 ÷ 37
Internal Spline data	38
Permissible shaft loads	38
Tacho connection	39
Order code	39

OPTIONS

- » Model- Disc valve, roll-gerotor
- » Flange with wheel mount
- » Short motor
- » Tacho connection
- » Speed sensing
- » Side and rear ports
- » Shafts- straight, splined and tapered
- » Metric and BSPP ports
- » Other special features

GENERAL

Displacement, [cm ³ /rev.]	161,1 ÷ 523,6
Max. Speed, [RPM]	240 ÷ 625
Max. Torque, [daNm]	47 ÷ 122
Max. Output, [kW]	26,5 ÷ 33,5
Max. Pressure Drop, [bar]	160 ÷ 200
Max. Oil Flow, [l/min]	100 ÷ 125
Min. Speed, [RPM]	5 ÷ 10
Permissible Shaft Loads, [daN]	P _a = 1000
Pressure fluid	Mineral based- HLP(DIN 51524) or HM(ISO 6743/4)
Temperature range, [°C]	-30 ÷ 90
Optimal Viscosity range, [mm ² /s]	20 ÷ 75
Filtration	ISO code 20/16 (Min. recommended fluid filtration of 25 micron)

Oil flow in drain line

Pressure drop (bar)	Viscosity (mm ² /s)	Oil flow in drain line (l/min)
140	20	2,5
	35	1,5
210	20	5
	35	3

Pressure Losses

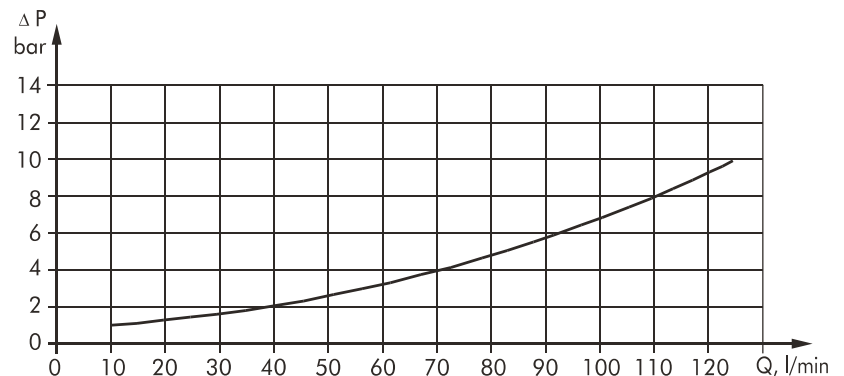

SPECIFICATION DATA

Type	MT 160	MT 200	MT 250	MT 315	MT 400	MT 500	
Displacement [cm ³ /rev.]	161,1	201,4	251,8	326,3	410,9	523,6	
Max. Speed, [RPM]	cont.	625	625	500	380	305	240
	Int.*	780	750	600	460	365	285
Max. Torque [daNm]	cont.	47	59	73	95	108	122
	Int.*	56	71	88	114	126	137
	peak**	66	82	102	133	144	160
Max. Output [kW]	cont.	26,5	33,5	33,5	33,5	30	26,5
	int.*	32	40	40	40	35	30
Max. Pressure Drop [bar]	cont.	200	200	200	200	180	160
	Int.*	240	240	240	240	210	180
	peak**	280	280	280	280	240	210
Max. Oil Flow [l/min]	cont.	100	125	125	125	125	125
	Int.*	125	150	150	150	150	150
Max. Inlet Pressure [bar]	cont.	210	210	210	210	210	210
	Int.*	250	250	250	250	250	250
	peak**	300	300	300	300	300	300
Max. Return Pressure without Drain Line or Max. Pressure in Drain Line , [bar]	cont. 0-100 RPM	75	75	75	75	75	75
	cont. 100-300 RPM	40	40	40	40	40	40
	cont. >300 RPM	20	20	20	20	20	-
Int.* 0-max. RPM	75	75	75	75	75	75	
Max. Return Pressure with Drain Line [bar]	cont.	140	140	140	140	140	140
	Int.*	175	175	175	175	175	175
	peak**	210	210	210	210	210	210
Max. Starting Pressure with Unloaded Shaft, [bar]	10	10	10	10	10	10	
Min. Starting Torque [daNm]	at max. press. drop cont.	34	43	53	74	84	95
	at max. press. drop Int.*	41	52	63	89	97	106
Min. Speed***, [RPM]	10	9	8	7	6	5	
Weight, [kg]	MT	20	20,5	21	22	23	24
	MTW	22	22,5	23	24	25	26
	MTS	15	15,5	16	17	18	19
	MTV	11	11,5	12	13	14	15

* Intermittent operation: the permissible values may occur for max. 10% of every minute.

** Peak load: the permissible values may occur for max. 1% of every minute.

*** For speeds of 5 RPM lower than given, consult factory or your regional manager.

- 1) Intermittent speed and intermittent pressure must not occur simultaneously.
- 2) Recommended filtration is per ISO cleanliness code 20/16. A nominal filtration of 25 micron or better.
- 3) Recommend using a premium quality, anti-wear type mineral based hydraulic oil, HLP(DIN51524) or HM(ISO6743/4).
If using synthetic fluids consult the factory for alternative seal materials.
- 4) Recommended minimum oil viscosity 13 mm²/s at 50°C.
- 5) Recommended maximum system operating temperature is 82°C.
- 6) To assure optimum motor life fill with fluid prior to loading and run at moderate load and speed for 10-15 minutes.

FUNCTION DIAGRAMS

MT 160

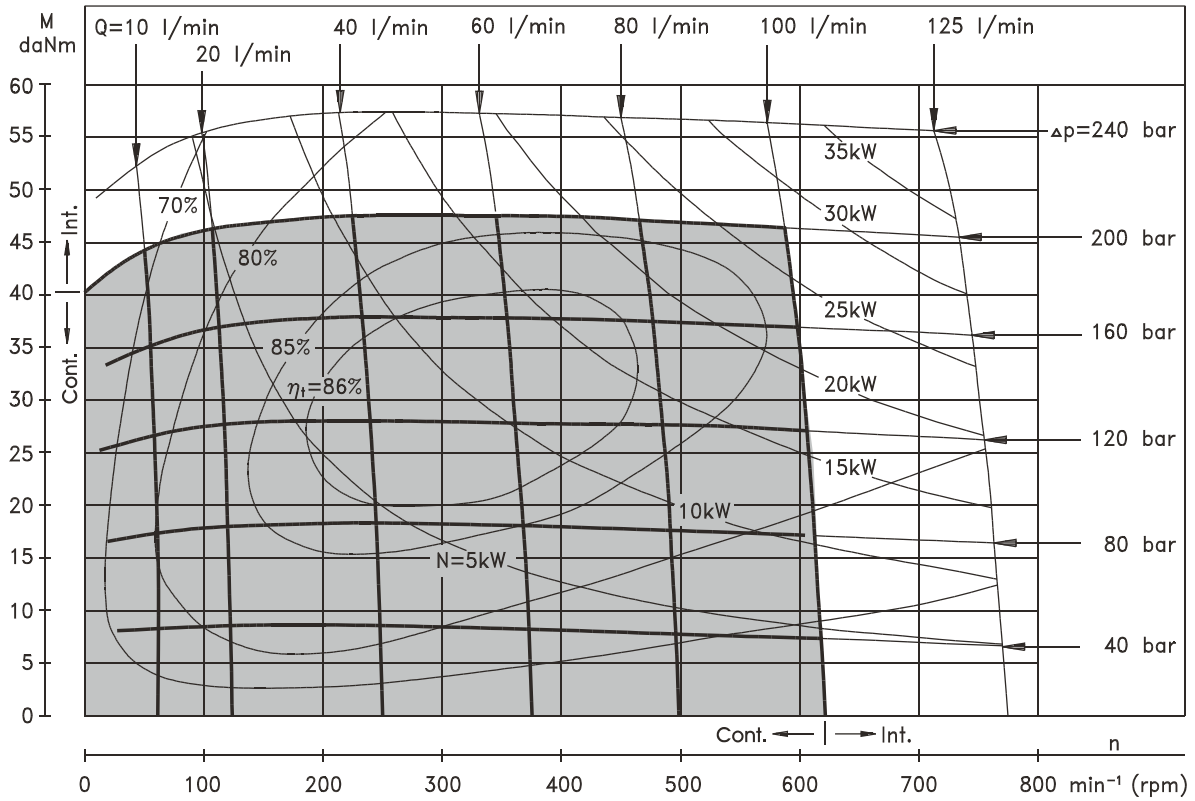

MT 200

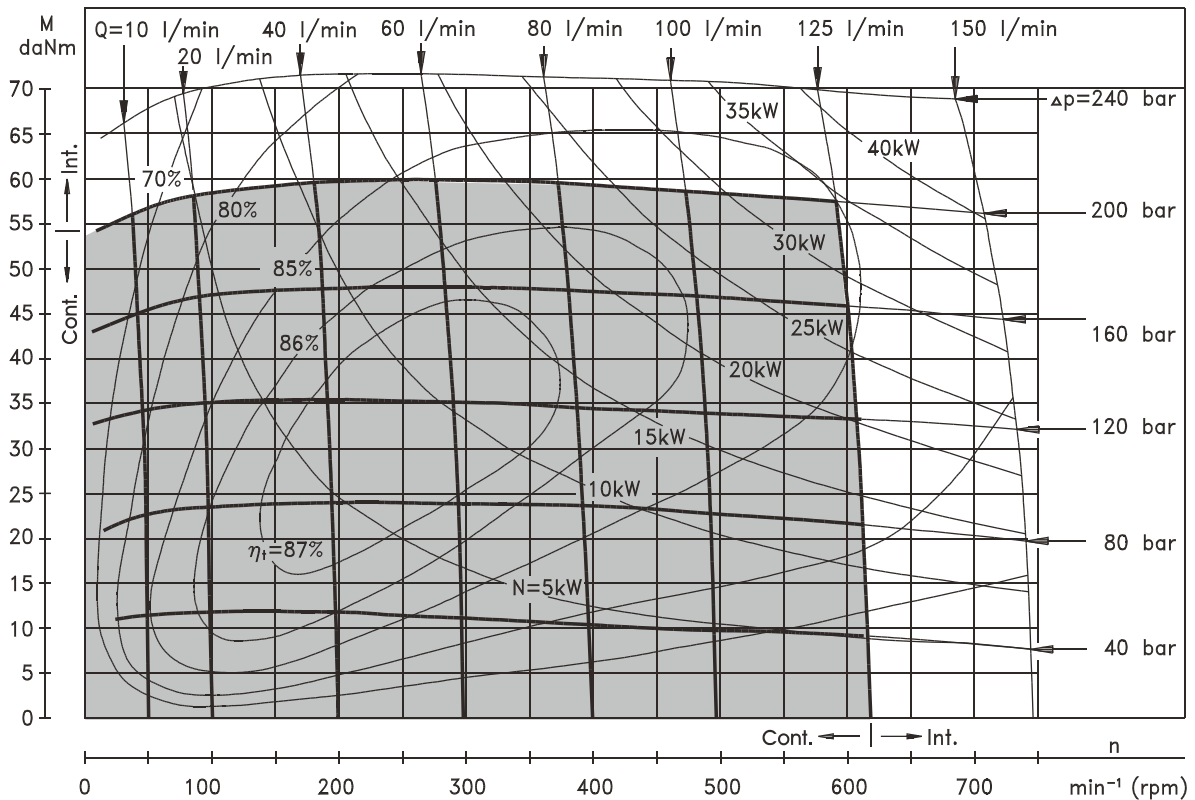

The function diagrams data was collected at back pressure $5 \div 10$ bar and oil with viscosity of $32 \text{ mm}^2/\text{s}$ at 50°C .

FUNCTION DIAGRAMS

MT 250

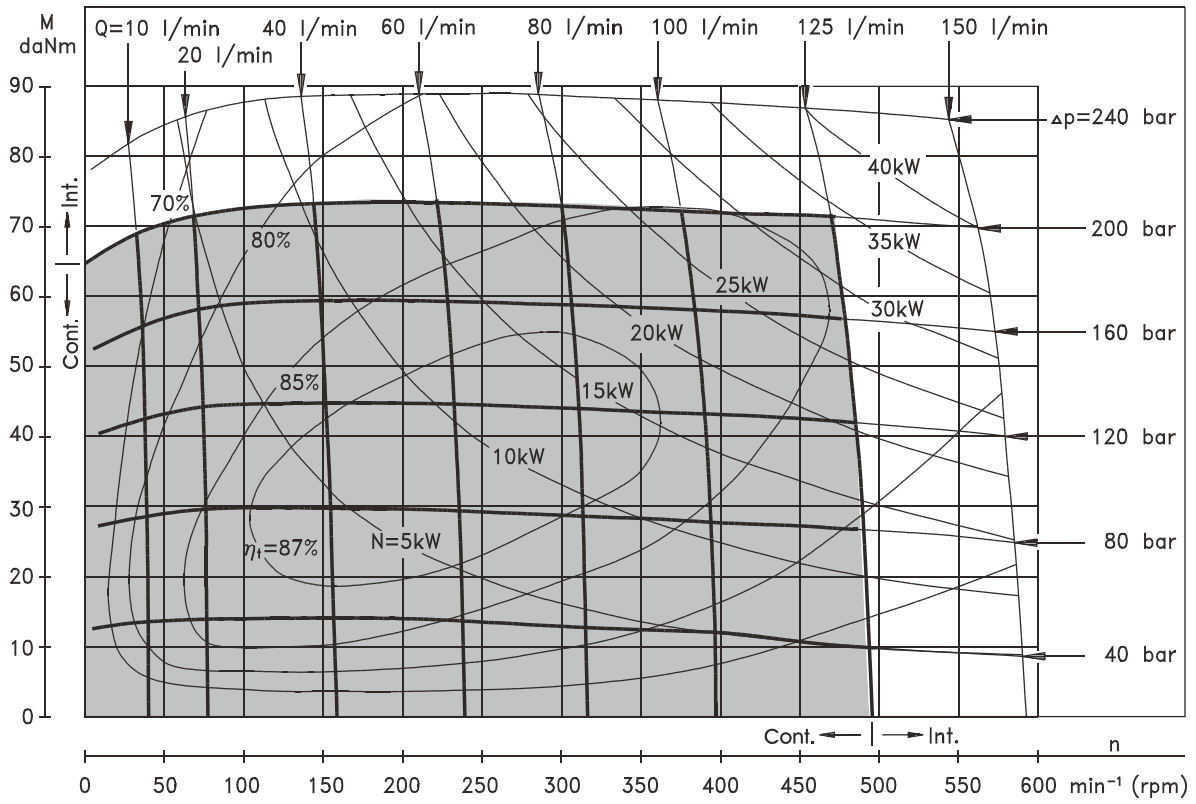

MT 315

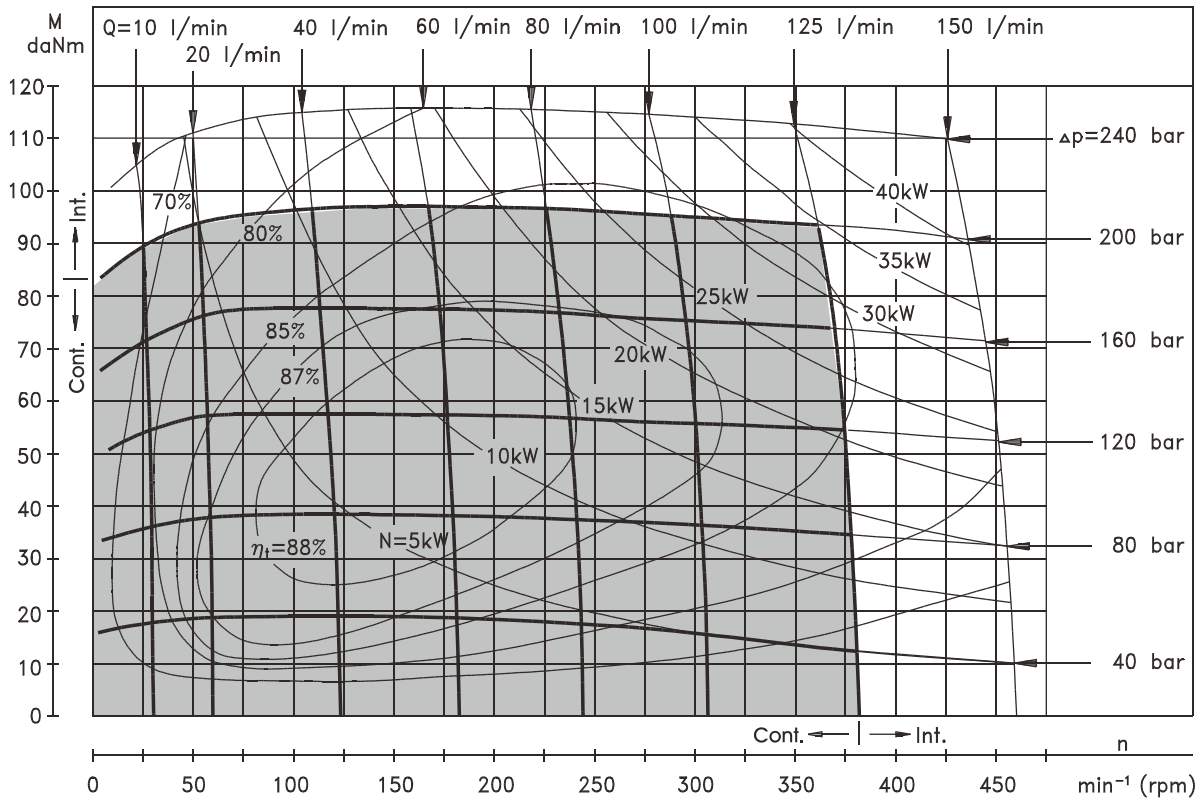

FUNCTION DIAGRAMS

MT 400

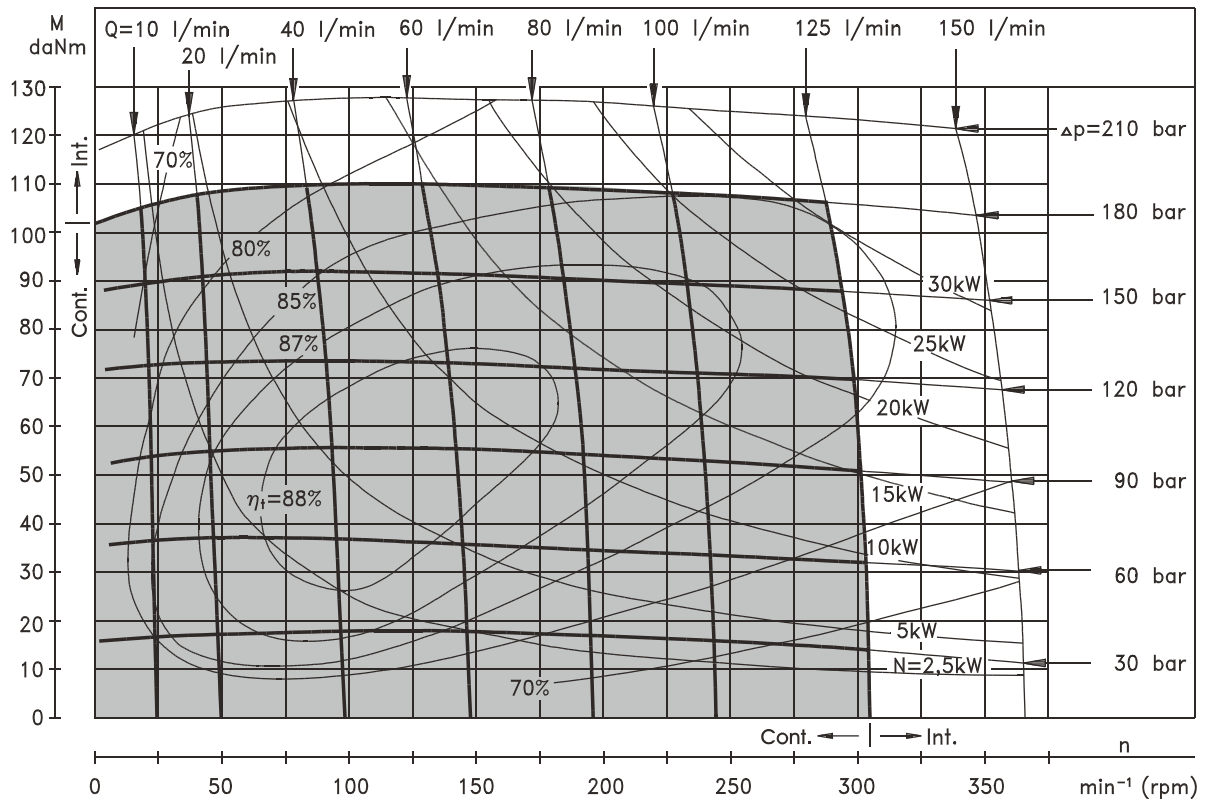

MT 500

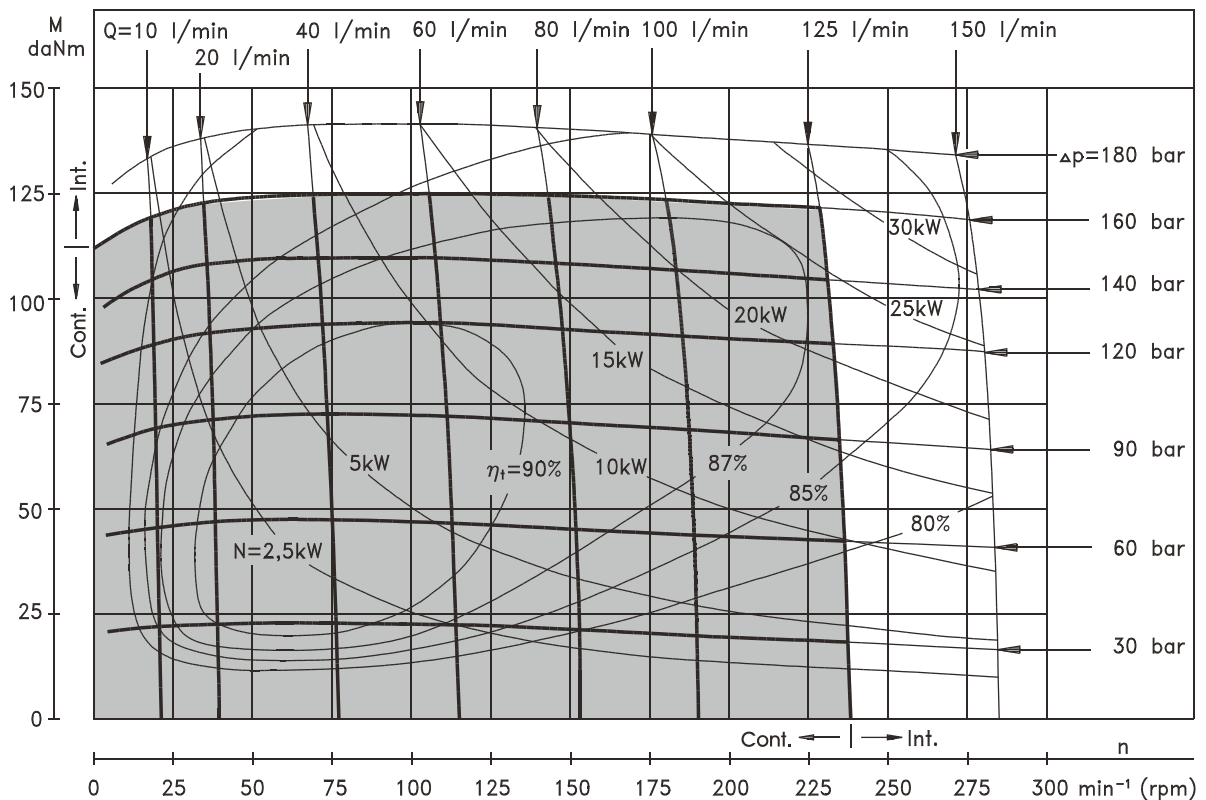

The function diagrams data was collected at back pressure $5 \div 10$ bar and oil with viscosity of $32 \text{ mm}^2/\text{s}$ at 50° C .

SHAFT EXTENSIONS

C - ϕ 40 straight, Parallel key A12x8x70 DIN 6885
Max. Torque 132,8 daNm

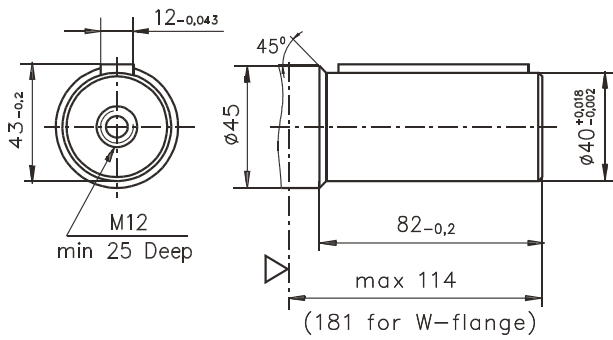

K -tapered 1:10, Parallel key B12x8x28 DIN 6885
Max. Torque 210,7 daNm

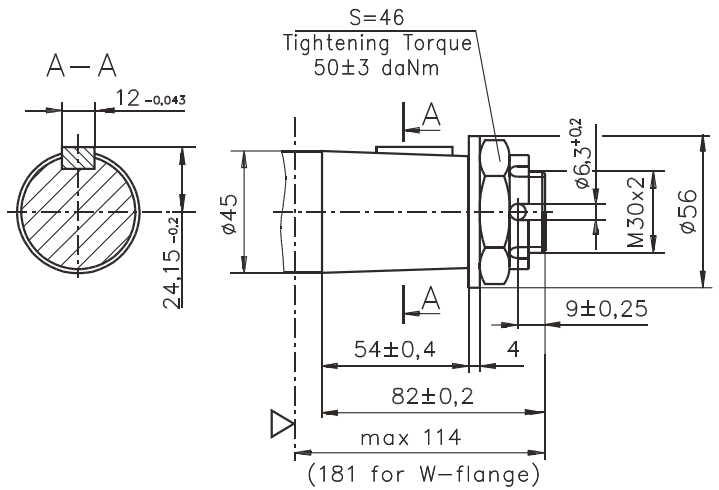

CO - ϕ 1 1/2" straight, Parallel key 3/8" x 3/8" x 2 1/4" BS46
Max. Torque 132,8 daNm

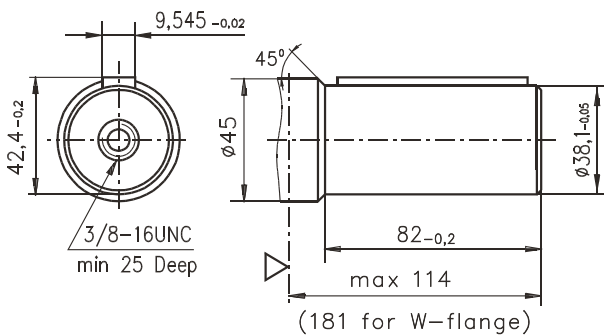

SH - ϕ 1 1/2" splined 17T, DP 12/24 ANSI B92.1-1976
Max. Torque 132,8 daNm

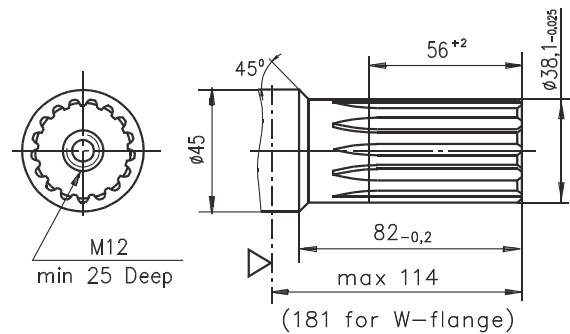

SL - ϕ 34,85 p.t.o. DIN 9611 Form 1
Max. Torque 77 daNm

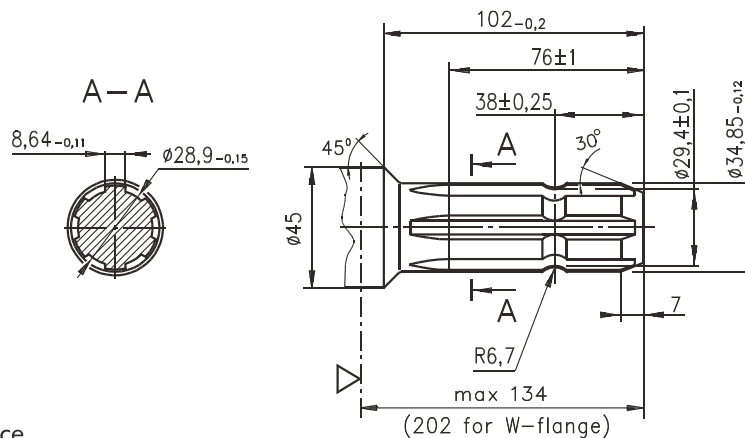

▽ - Motor Mounting Surface

DIMENSIONS AND MOUNTING DATA - MTS and MTV

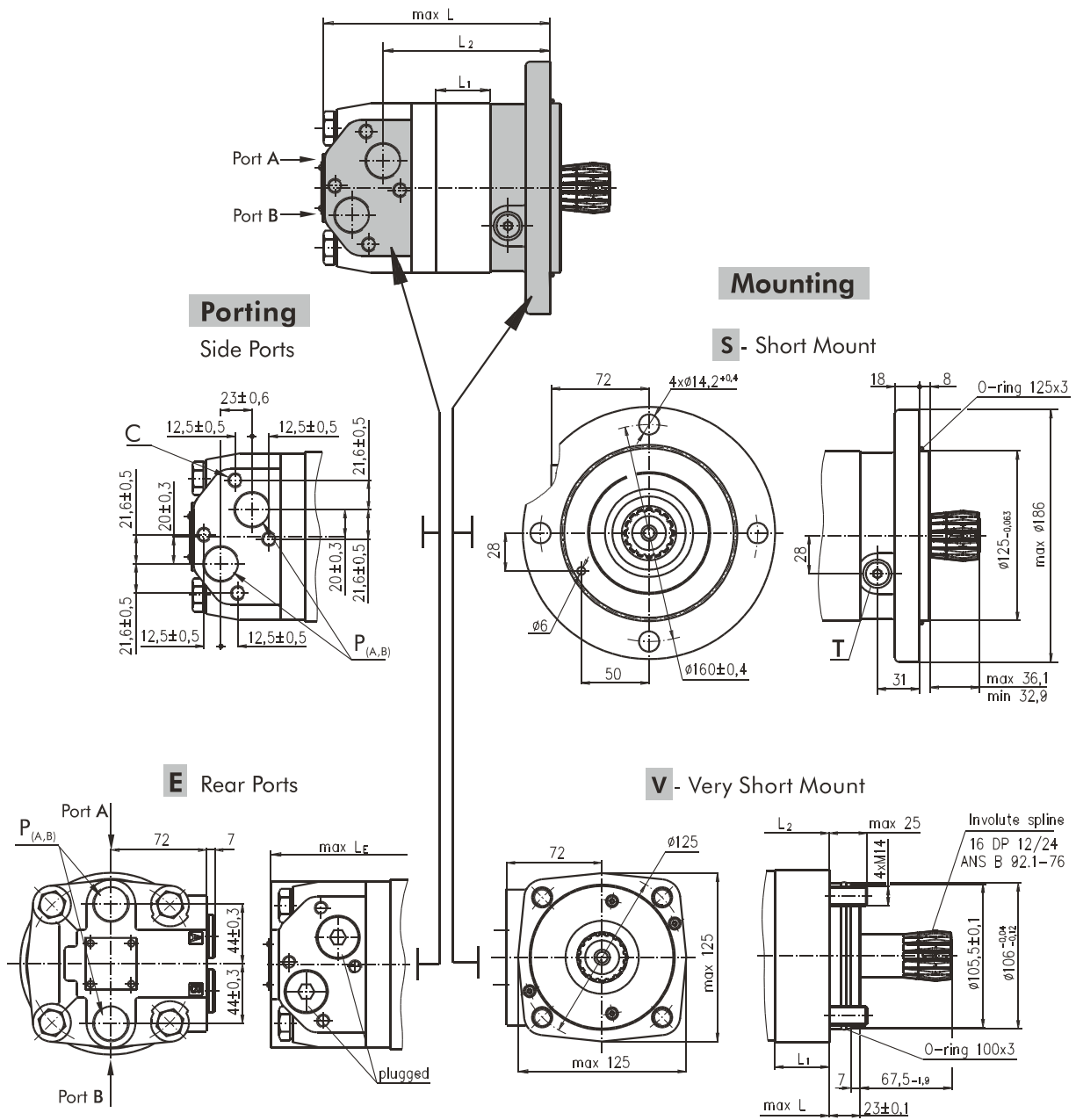

Standard Rotation
Viewed from Shaft End
Port A Pressurized - CW
Port B Pressurized - CCW

Reverse Rotation
Viewed from Shaft End
Port A Pressurized - CCW
Port B Pressurized - CW

C: 4xM10-10 mm depth
P_(A,B): 2xG3/4 or 2xM27x2-17 mm depth
T: G 1/4 or M14x1,5 - 12 mm depth (plugged)

Type	L, mm	Type	L, mm	L ₂ , mm	Type	L, mm	Type	L, mm	L ₂ , mm	L ₁ , mm
MTS 160	151	MTSE 160	156	103	MTV 160	106	MTVE 160	111	58,5	20
MTS 200	156	MTSE 200	161	108	MTV 200	111	MTVE 200	116	63,5	25
MTS 250	162	MTSE 250	167	115	MTV 250	117	MTVE 250	122	70,8	31,3
MTS 315	171	MTSE 315	176	123	MTV 315	126	MTVE 315	131	79	40,5
MTS 400	182	MTSE 400	187	134	MTV 400	137	MTVE 400	142	89,5	51
MTS 500	196	MTSE 500	201	149	MTV 500	151	MTVE 500	156	103,5	65

DIMENSIONS OF THE ATTACHED COMPONENT

MTS

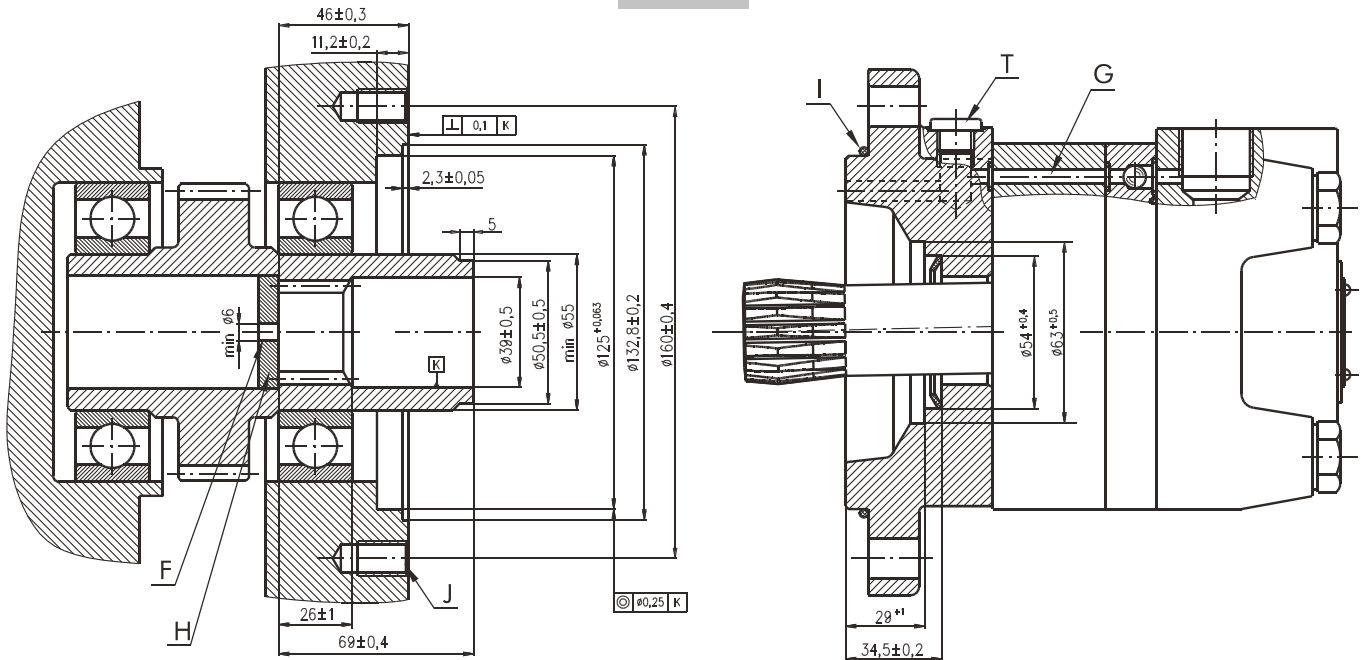

F: Oil circulation hole
G: Internal drain channel
H: Hardened stop plate

I: O- Ring 125x3mm
J: 4xM12-18 mm depth, 90°
T: Drain connection G1/4 or M14x1,5

MTV

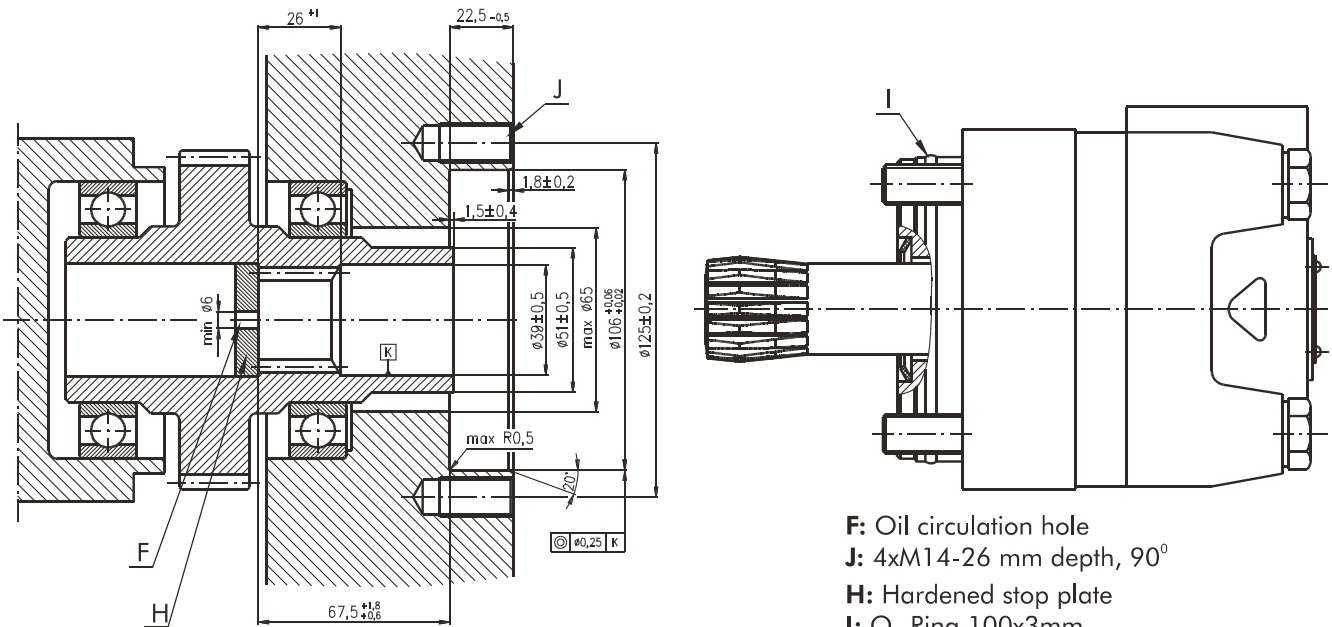

F: Oil circulation hole
J: 4xM14-26 mm depth, 90°
H: Hardened stop plate
I: O- Ring 100x3mm

DRAIN CONNECTION

A drain line ought to be used when pressure in the return line can exceed the permissible pressure. It can be connected:

- For MTS at the drain port of the motor;
- For MTV at the drain connection of the attached component. The maximum pressure in the drain line is limited by the attached component and its shaft seal.

The drain line must be possible for oil to flow freely between motor and attached component and must be led to the tank. The maximum pressure in the drain line is limited by the attached component and its seal.

INTERNAL SPLINE DATA FOR THE ATTACHED COMPONENT

Standard ANSI B92.1-1976, class 5
[$m=2.1166$; corrected $x.m=+1,0$]

Fillet Root Side Fit		mm
Number of Teeth	z	16
Diametral Pitch	DP	12/24
Pressure Angle		30°
Pitch Dia.	D	33,8656
Major Dia.	D _{ri}	38,4 ^{+0,4}
Minor Dia.	D _i	32,15 ^{+0,04}
Space Width [Circular]	Lo	4,516±0,037
Fillet Radius	R	0,5
Max. Measurement between Pin	L	26,9 ^{+0,10}
Pin Dia.	d	4,835±0,001

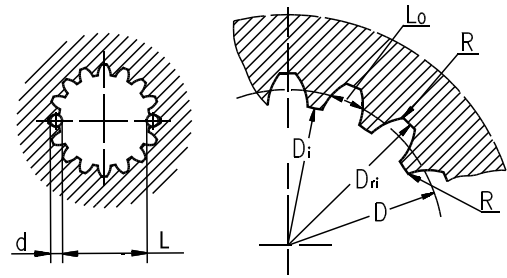

Hardening Specification:
HRC 60±2
HRC 52
0,7±0,2 mm effective case depth
Material 20 MoCr4 DIN 17210 or better

PERMISSIBLE SHAFT LOADS

The output shaft runs in tapered bearings that permit high axial and radial forces. Curve "1" shows max. radial shaft load. Any shaft load exceeding the values quoted in the curve will seriously reduce motor life. The two other curves apply to a B10 bearing life of 3000 hours at 200 RPM.

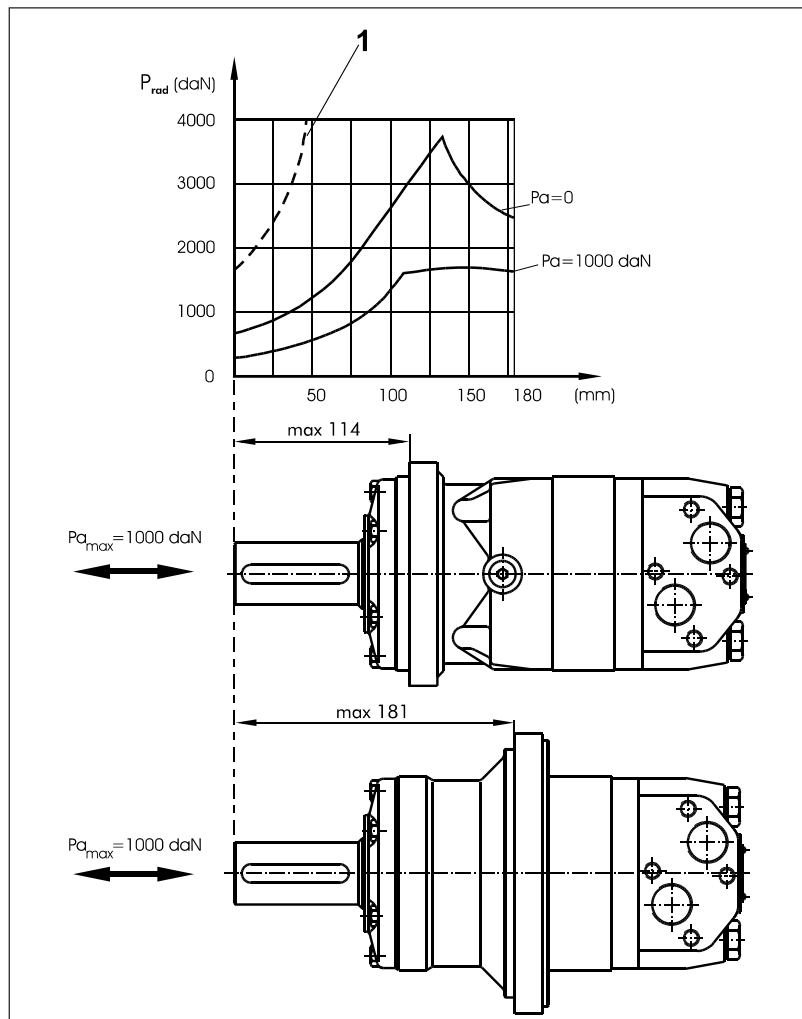

MOTORS WITH TACHO CONNECTION

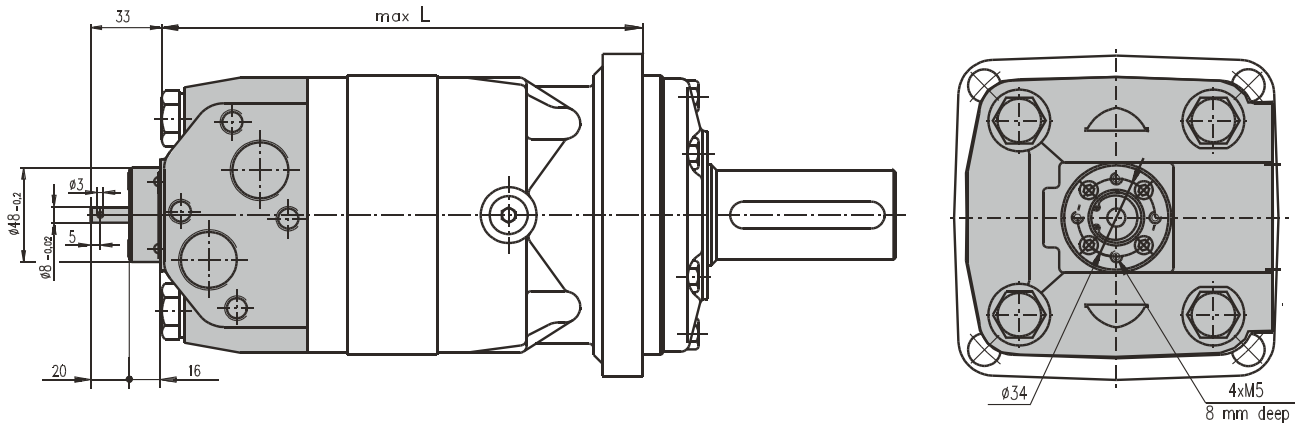

ORDER CODE

	1	2	3	4	5	6	7
M T							

Pos. 1 - Mounting Flange

omit - Square mount, four holes

S - Short mount

V - Very short mount

W - Wheel mount

Pos. 2 - Port type

omit - Side ports

E - Rear ports

Pos. 3 - Displacement code

160 - 161,1[cm³/rev]

200 - 201,4[cm³/rev]

250 - 251,8[cm³/rev]

315 - 326,3[cm³/rev]

400 - 410,9[cm³/rev]

500 - 523,6[cm³/rev]

Pos. 4 - Shaft Extensions*

C - ø40 straight, Parallel key A12x8x70 DIN6885

CO - ø1½" straight, Parallel key 3/8"x3/8"x2¼" BS46

K - ø45 tapered 1:10, Parallel key B12x8x28 DIN6885

SL - ø34,85 p.t.o. DIN 9611 Form 1

SH - ø1½" splined 17T ANSI B92.1-1976

Pos. 5 - Ports

omit - BSPP (ISO 228)

M - Metric (ISO 262)

Pos. 6 - Special Features (see page 50)

Pos. 7 - Design Series

omit - Factory specified

NOTES:

* The permissible output torque for shafts must not be exceeded!

The hydraulic motors are mangano-phosphatized as standard.