

Product Series 03

Concrete Mixer Hydraulic Oil Cooler



FLJ-SERIES bar plate oil cooler through 16 years of market tests, after 280 times upgrade improved and now is mature global standard series products, Can be used in any brand of concrete mixer truck and Engineering machinery

- Optional different heat transfer model
- Optional different oil box size (12L-36L)
- Optional different types of motor (DC12/24v)
- Optional different temperature sensor (77°F - 176°F)
- Optional different filtration precision filter
- Optional long service life of the motor (up to 20000 hours)

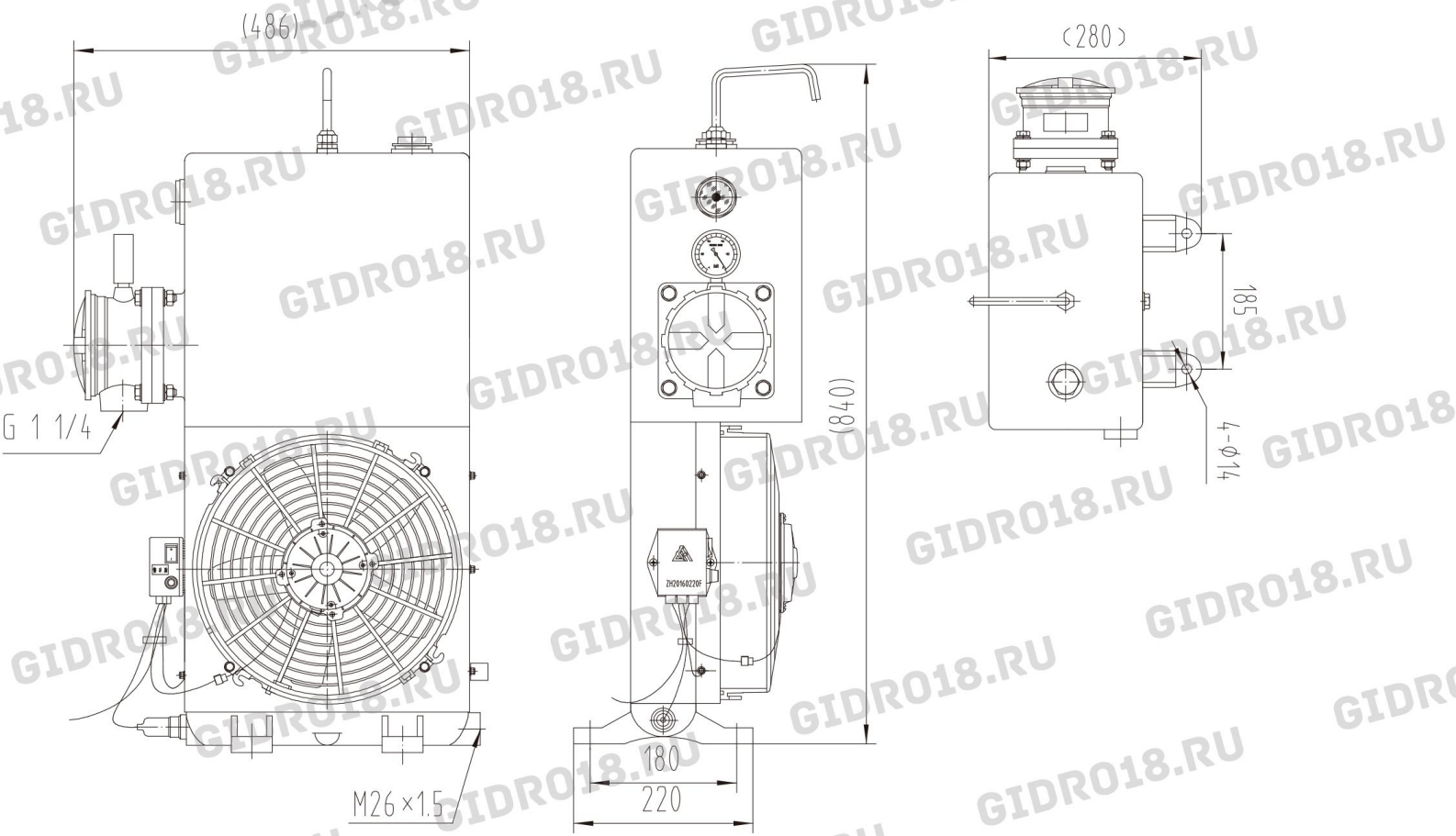
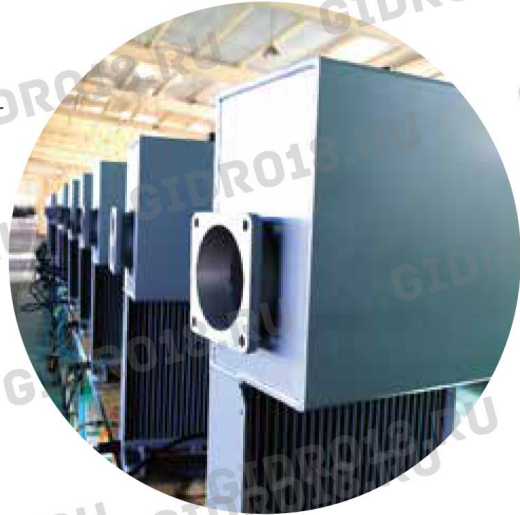

Model	OilIn (mm)	OilOut (mm)	Power Fan (w)	Voltage (V)	Work Temp (°C)	Oil Box	Filtration Accuracy (µm)	Waterproof	Install Dimension (mm)
FLJ3	M26x1.5	G1 1/4	120	12/24	50-55	12	10	IP68	185x180
FLJ6	M26x1.5	G1 1/4	240	12/24	50-55	15	10	IP68	185x180
FLJ8	M26x1.5	G1 1/4	240	12/24	50-55	18	10	IP68	185x180
FLJ10	M26x1.5	G1 1/4	240	12/24	50-55	21	10	IP68	185x180
FLJ12	M26x1.5	G1 1/4	240	12/24	50-55	26	10	IP68	185x180 305x200
FLJ13	M26x1.5	G1 1/4	240	12/24	50-55	32	10	IP68	185x180 305x240
FLJ15	M26x1.5	G1 1/4	240	12/24	50-55	36	10	IP68	185x180 305x240

